



OPERATION INSTRUCTION

Vernier Caliper Series 1205

Caution: Do not measure the workpiece if it is rotating, this is dangerous and measuring faces will be worn out

Graduation	Accuracy
0.02mm/0.001"	±0.02mm (Range: 0-100mm/0-4") ±0.03mm (Range: 100-300mm/4-12")
0.05mm/1/128"	±0.05mm (Range: 0-300mm/0-12")

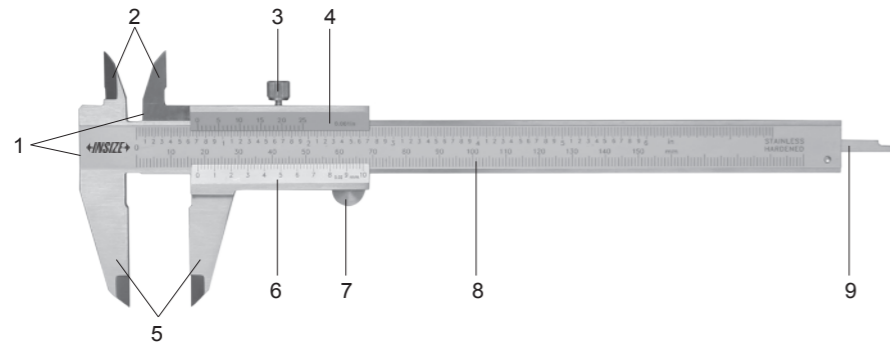

- 1-Step measuring faces
- 2-Internal measuring jaws
- 3-Locking screw
- 4-Slider
- 5-External measuring jaws
- 6-Vernier with vernier scale
- 7-Thumb clamp
- 8-Beam
- 9-Depth measuring bar

1. Measurement

External measurement Internal measurement Step measurement Depth measurement

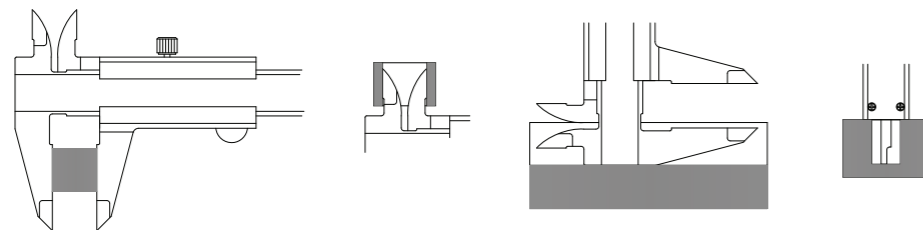

- Please clean the measuring faces and beam with soft cloth, then close the external jaws, make sure that the zero lines of the vernier and main scales coincide and there is no slit observed between the jaws against the light.
- To get accurate measurement, it is necessary to control the force. During measurement, please always apply constant and proper force on the thumb clamp. The measuring jaws should "hold" the workpiece and can still "slide" on the workpiece.
- The reading is obtained by adding the reading of the vernier scale to that of the main scale. Take the vernier scale reading at the graduation which coincides with the one on the main scale. Details please refer to following figures.

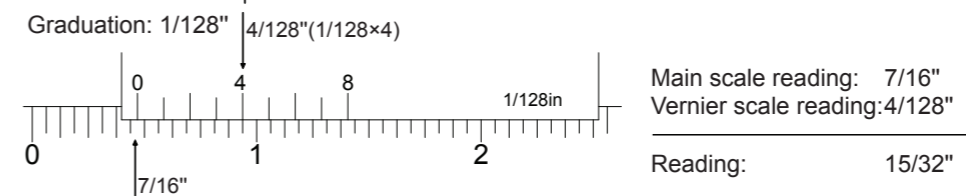
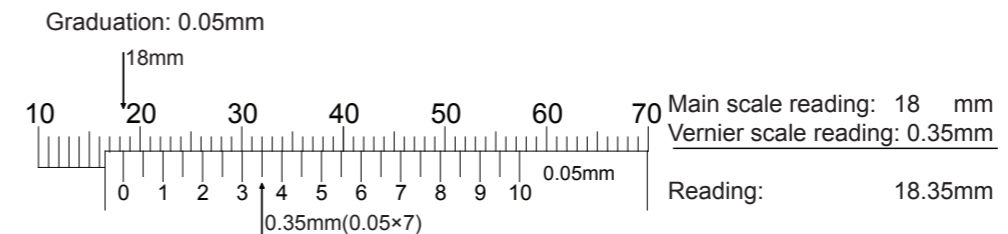
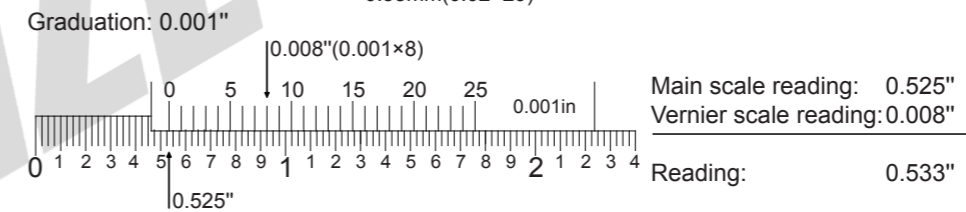
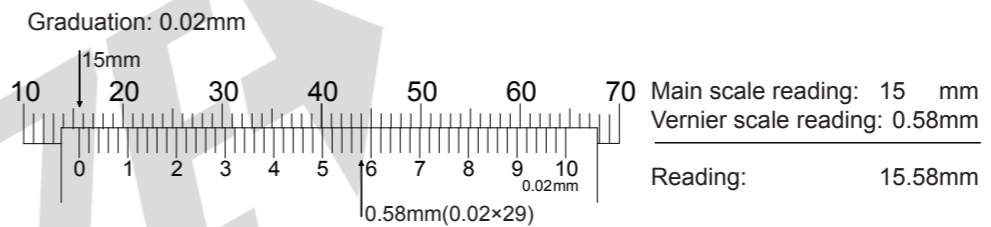

MN-1205S-E