

Caution: Prevent liquid from getting into indicator to damage electronics.

Code	Range	Accuracy	Hysteresis	Resolution	Remark
2114-5F	5mm/0.2"	20μm	10μm	0.01mm/0.0005"	flat back
2114-51F	5mm/0.2"	5μm	2μm	0.001mm/0.00005"	flat back

- 1-"in/mm" button
- 2-Battery cover
- 3-LCD display
- 4-USB data output
- 5-"0/ON" button
- 6-"ABS" button
- 7-Stem(diameter Ø8mm)
- 8-Spindle
- 9-Contact point(thread M2.5X0.45)

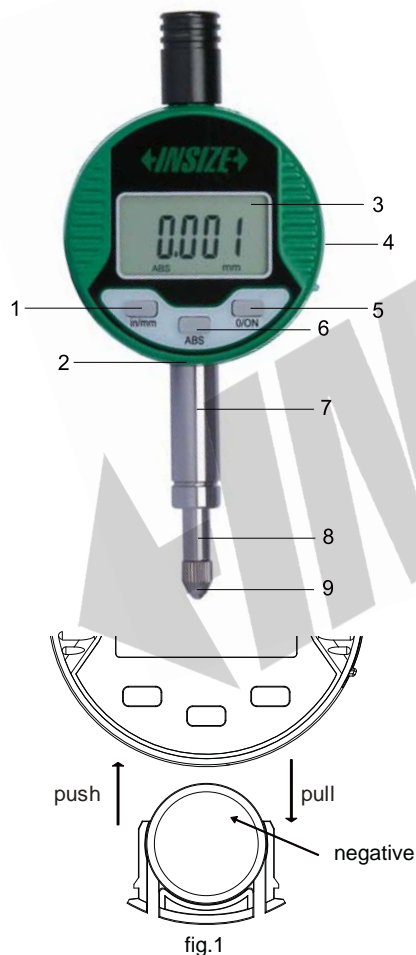

1. Install and remove battery(CR1632), the negative side of battery should face out(fig.1).

2. Buttons:

- 'in/mm'--- short press for inch/metric conversion
long press to change measuring direction
- 'ABS' --- short press for absolute/incremental measurement
long press to preset data
- '0/ON'--- short press to turn on when power is off
short press to set zero when power is on
long press to turn off

3. Automatic power off in about 6 hours. Press "0/ON" button to turn on indicator.

4. Digital indicator should be mounted on a rigid holder to use.

5. Clamping: clamping the stem for flat back dial indicator. If the dial indicator is mounted by clamping the stem, please do not apply excessive clamping force, which will affect the movement of the spindle.

6. During measurement, the spindle should be vertical to the workpiece surface, otherwise, the measurement may not be correct.
Caution: please do not move the spindle quickly or apply lateral force on the spindle.

7. After measurement, please apply oil the contact point. The spindle should not be oiled, otherwise, the movement of the spindle will not be smooth.

8. If the digital indicator drops or be shocked, please inspect the measuring accuracy before using.

9. Optional accessories: SPC cable(7306-40, 7302-SPC3A or 7305-SPC1A), contact points(series 6282).

In order to get accurate measurement, it is necessary to choose contact point according to the shape of the workpiece. Measuring columned workpiece should choose knife edge point, measuring spherical workpiece should choose flat point, the needle point should be chosen when measuring concave or complex shape workpiece.

10. One battery can last for one year use. If there is nothing on display or digits blurring, battery voltage is too low, please replace battery. If the digits do not change when buttons are pressed or spindle is moved, take out battery and put it back after 1 minute.If the indicator is not be used for a long period of time, please remove the battery. Otherwise, liquid may leak from the battery and damage the indicator.

11. Working temperature is 0-40°C/32-104°F, relative humidity should not exceed 80%.